



Spritzgiessautomaten



MORE ECONOMICAL.
QUIETER.
FASTER.
MORE PRECISE.

BOY injection molding machines
with servo-motor pump drive

BOY 55 E • BOY 90 E

BOY-injection molding machines with servo-motor pump drive

The BOY 55 E and BOY 90 E injection molding machines are our largest tonnage models.

From the beginning we have embraced and offered new technologies that meet energy saving requirements.

The introduction of the servo-motor pump drive marks another breakthrough in this regard.

BOY injection molding machines operate with high precision, are compact, and can easily be equipped for automation. They also have very low operating costs and extremely low machine hour rates.

The above features are achieved by the following:

- Favourable price / performance ratio
- Compact design
- Reliability and ease of maintenance
- Low energy consumption

A detailed description of the BOY 55 and BOY 90, as well as the Procan ALPHA® control can be found in our „Compact Quality“ brochure.

Basic data for the cost comparison on the right is as follows:

- Annual degree of utilization: 6,000 h
- Depreciation over 5 years
- Cost for space: € 60.00 per m²
- Energy cost: € 0.10/kWh
- Maintenance rate: 5 %
- Interest rate: 6 %

Comparison of machine hour rates

(for machines with 500/550 kN clamping force)

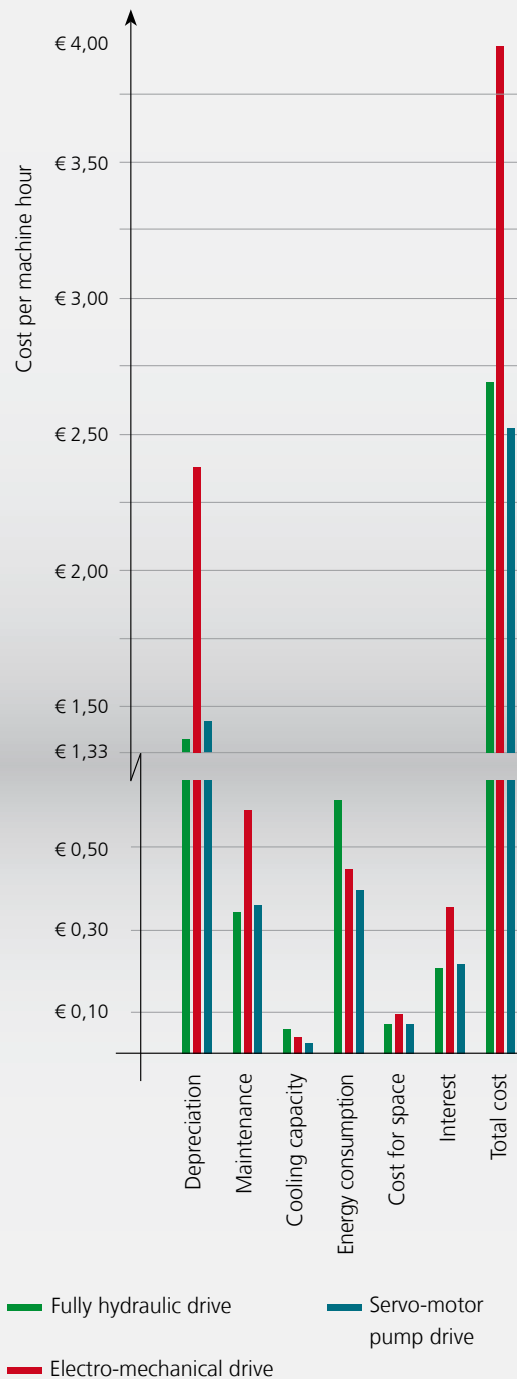

Method of operation

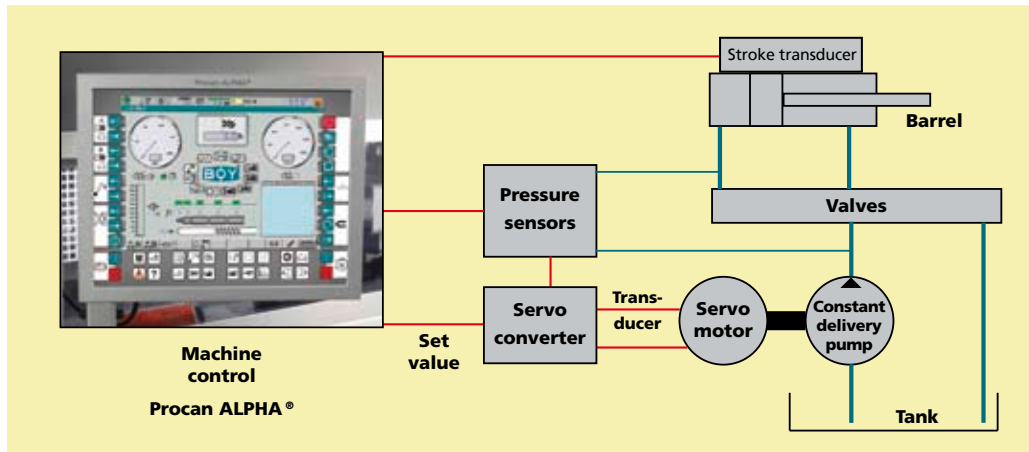

The distinctive feature of the complete system (converter / motor / pump) is its compact design.

A gear pump is driven by a special servo motor. Volume and pressure control are dynamically effected when the motor speeds are adjusted. When neither oil nor pressure are needed, the motor switches off and no longer requires energy.

Motor speed is only as high as a respective cycle phase requires, so at any given moment, the motor is performing in an optimum, energy-efficient manner.

The same is true during the pressure control phase of the cycle (holding pressure). Again, the motor speed dynamically adjusts, so the energy consumed is exactly the amount needed to maintain the pressure control. As a result, the energy requirement, noise level, and hydraulic energy are significantly reduced.

The patented servo-motor, optimized for this type of application, is controlled by a servo converter that receives pressure and volume control data from the control system. The actual value of the hydraulic pressure is transmitted to and controlled by the servo converter. It is here where the many dynamic and complex pressure and speed control requirements are processed in the most efficient

manner. In order to capably handle these tasks, the motor is equipped with an angular acceleration of more than $3,500 \text{ rad/s}^2$.

A synchronous servo motor with a special, patented arrangement of the magnets is used. With this magnet arrangement, the torque can be doubled without increasing the motor current. In addition, this design reduces to a minimum the heat up phase of the motor thereby requiring less energy for cooling and generally improves overall efficiency. In all operating modes, the motor works in an extremely energy-saving manner.

Some of the kinetic energy that is produced during the slowdown phase is stored in the intermediate circuit of the converter and reused for the next function, i.e., acceleration of an axis.

The combined effect of the highly efficient motor, the special converter control, and a motor speed that adjusts to a required volume throughput, allows the pump to always maintain an optimum mode of operation.

Advantages

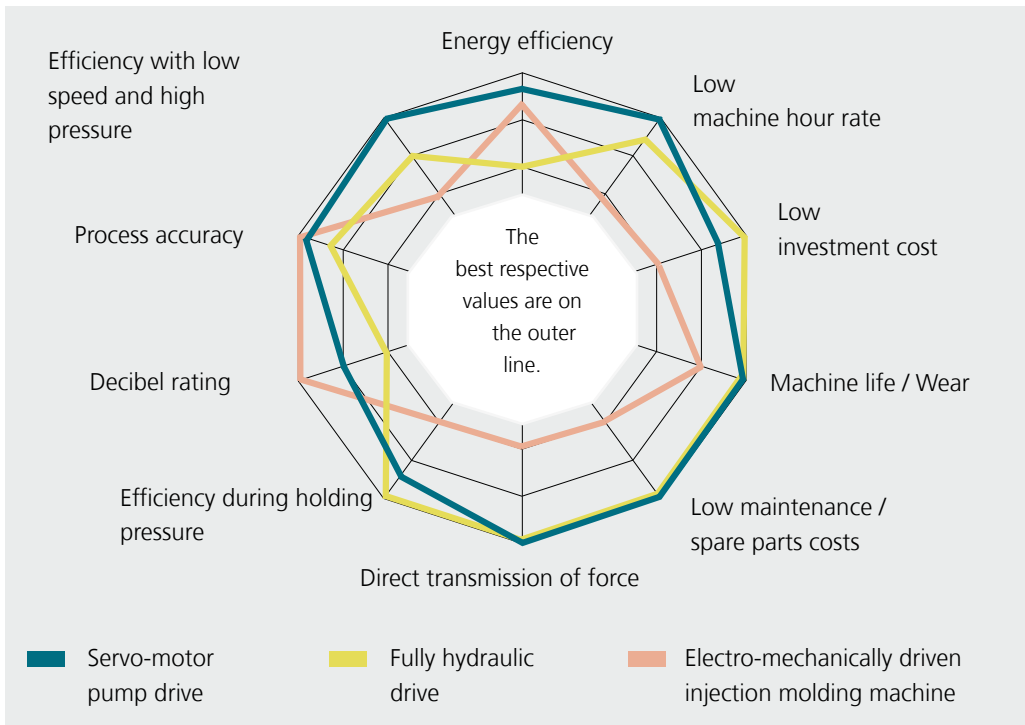

The use of a servo-motor pump drive makes it possible to achieve and/or surpass the positive features of electro-mechanical machines without acquiring their inherent disadvantages such as high investment and spare parts costs, wear problems, and high connected load.

Compared to machines with electronically controlled variable displacement pump, the energy consumption of the drive is cut in half. It is even lower than that of electro-mechanical machines which, furthermore, have a markedly higher connected load.

This new drive technology also ensures that distinct improvements with regard to noise level, precision, and dynamics are achieved.

The noise level is reduced as much as 20 %. This is achieved by:

- Motor speed adjustments and noiseless when the motor is inactive.

- Special motor torque control
- Use of constant delivery pumps
- Prevention of pressure variations
- Prevention of abrupt sequencing via the adaptation of switch sequencing of the valves

Improved precision and dynamics are achieved by:

- More precise, repeatable acceleration and slow-down performance of the motor-pump unit. Response time is 70 ms for an alteration of the set value from standstill to full speed and thus to a maximum throughput rate. The reduction of speed is effected with identical dynamics.
- The optimized motor with high torque features a low moment of inertia, as does the constant delivery pump.
- Converter with high reaction dynamics.

Practical, comparative measurements

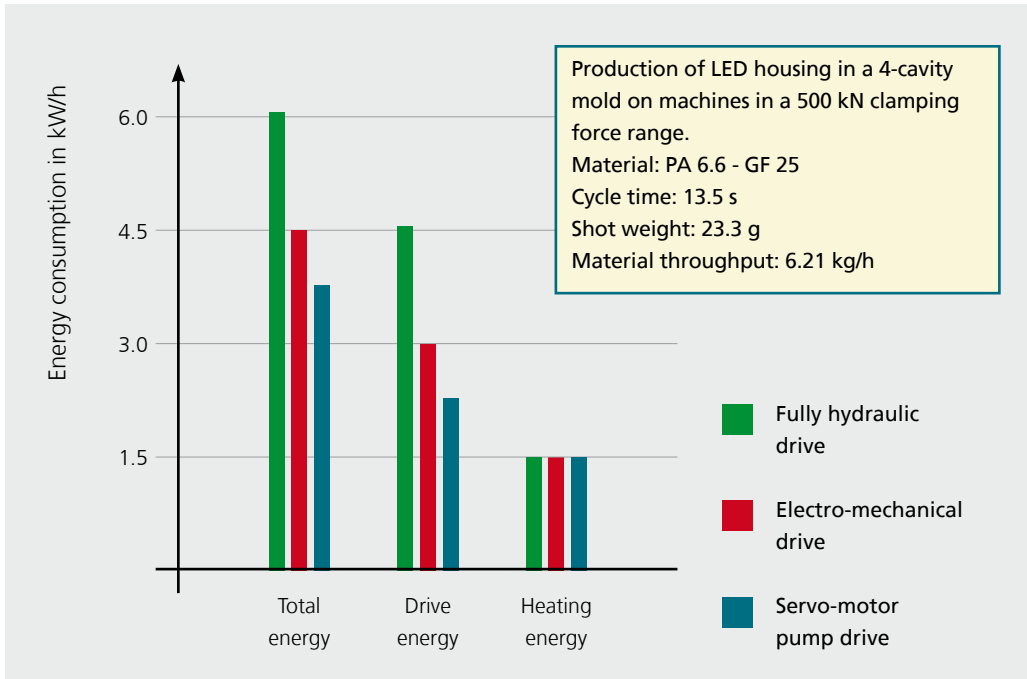

Uniform results





By measuring the weight of 200 molded parts, the consistency of the parts confirmed the precise repeatability of the machine.

The average value of the parts was 51.90 g. Thus the maximum deviation of 0.06 g (upwards as well as downwards) is only 0.115 % of the average value.

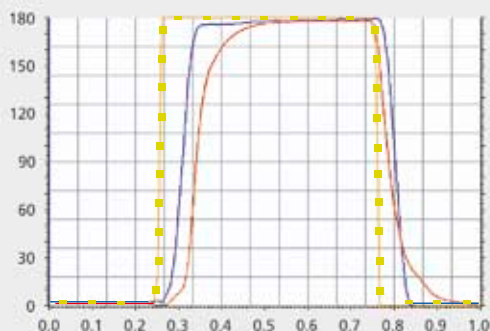
Reaction times



Increasing the pressure from 0 to 180 bar takes no more than 100 ms. To reduce the pressure from 180 bar to an actual 0 bar, 80 ms are needed.

-  Set value
-  BOY „E“ series
-  Comparative value of fully hydraulic machine



Spritzgiessautomaten

Technical data

	BOY 55 E	BOY 90 E
Size denominations as per EUROMAP:	550-52 / 550-79 / 550-205	900-205 / 900-370
Clamping force:	60.5 US Tons	99 US Tons
Distance between platens:	25.6 in	28.55 in
Maximum mold opening stroke:	15.75 in	18.70 in
Daylight between tie bars (h x v):	14.18 x 13.19 in	16.93 x 14.18 in
Maximum shot weight (PS):	5.57 oz	8.89 oz
Maximum stroke volume (theoretical):	10.15 in ³	17.11 in ³
Screw diameter:	18 / 22 / 24 / 28 / 32 / 38 and 42 mm	28 / 32 / 36 / 42 and 48 mm

A servo-electric screw drive is available as an option.

BOY Demonstration Center Put us to the test

We are proud to present the quality of BOY machines in an environment that is perfectly representative of actual field performance.

Our well equipped Exton based demonstration center provides you with the opportunity to gather information about our complete line of injection molding machines.

Save time and money by testing our machines under operating conditions. Let BOY show you how our customer oriented service program works for you.



Boy Machines, Inc.
199 Philips Road
Exton, PA 19341

Phone: 1-610-363-9121
Fax: 1-610-363-0163
E-Mail: sales@boymachines.com
www.boymachines.com