

## Innovative into the Future – BOY-Injectioneering



SP 14 / SP 26



SP 11 – SP 96

---

Injection units BOY 2C XS  
BOY 2C S

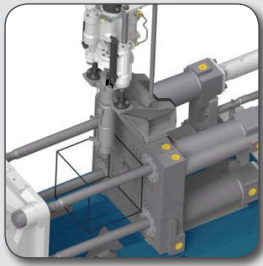

Injection unit in vertical position on top of the fixed platen



Injection unit in vertical / inclined position on top of the mold

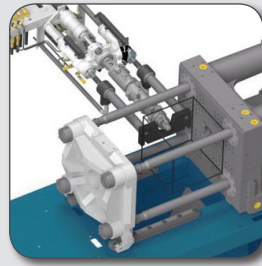

Horizontal mounting at the side of the mold (horizontal L-Position)

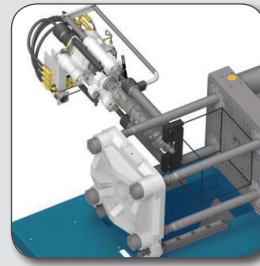

Vertical mounting



Injection unit in slidable vertical position on top of the fixed platen

The injection unit for the 2nd component is based of the ultra compact **BOY XS E**. It is equipped with its own hydraulic drive and control. Depending on the execution this unit offers a plasticizing volume of up to 76.4 cm<sup>3</sup>.

The drive unit, which includes the control, is positioned next to the basic machine. Fixed wheels make the unit easy to move to other BOY injection molding machines or machines from other suppliers that are processing a 2nd component. The controls of both machines communicate with each other via I/O-interface or special adapter cable. This assures a seamless process during the entire injection molding cycle.

Depending on the application, the 2nd injection unit can be arranged in various positions. This is done space-saving in vertical position on horizontal machines; also a lateral

mounting of the injection unit is possible (see graphic representation above).

The open nozzle plasticizing unit is connected to the injection unit for the 2nd component through a corresponding adjustable high-pressure hose line (4 m or 6 m).

The TFT display of the 2nd injection unit is equipped with a longer cable. Therefore, the placement of the monitor can be arranged at the user-side of the basic machine - directly next to the basic machine's Procan ALPHA<sup>®</sup> monitor.



- 1 The machine design features the best ergonomics and efficient operation.
- 2 Alternatively, the injection unit can also be equipped with sturdy rollers and castor wheels.
- 3 Flexible positioning of the injection unit on the basic machine.
- 4 Optimum control technology with intuitive operation concept.
- 5 Robust machine design with integrated oil tank.

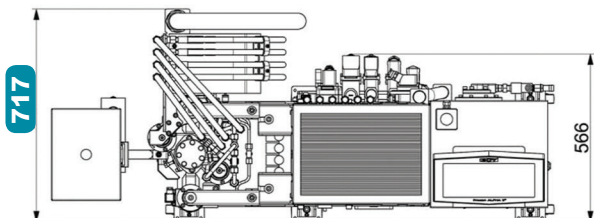
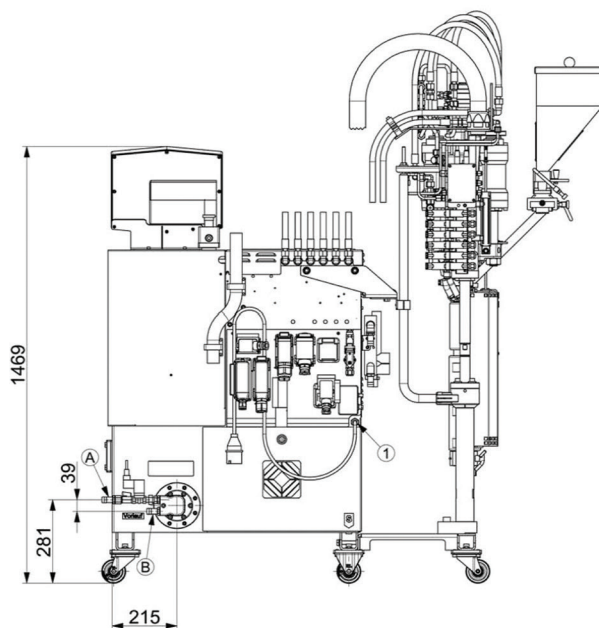
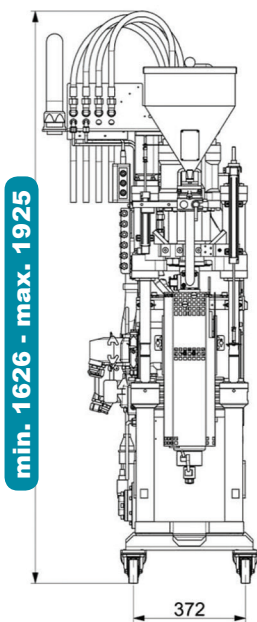
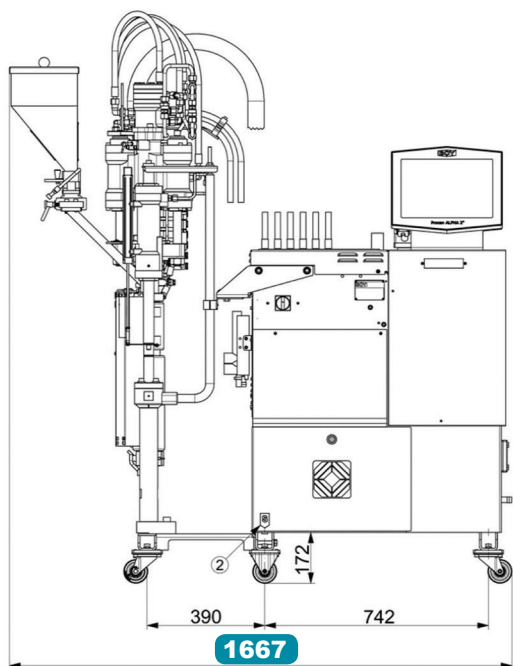

**Additional machine types available:**

Model	2C XS		2C S			2C M
Injection unit	SP 14	SP 11	SP 16	SP 45	SP 56	SP 215
Screw diameter in mm	12	12	14	18	18	28
	16			22		32
						38

**Technical Data – standard version<sup>1)</sup>**

Injection unit for processing thermoplastics		SP 14 (2C XS)	SP 81 (BOY 2C S)	SP 96 (BOY 2C S)		
Screw diameter	mm	14	22	24	28	32
Screw- L/D-ratio		16.9	17.5	22	18.6	16.3
Max. stroke volume (theoretical)	in <sup>3</sup>	0.38	1.86	2.62	3.57	4.66
Max. shot weight in PS (theoretical)	oz	0.2	1	1.4	1.9	2.5
Injection force	US Tons	4	11.4	11.4		
Injection volume flow	in <sup>3</sup> / sec	1.9	2.1	2.5	3.4	4.5
Max. spec. injection pressure	psi	33330	38522	32358	23772	18202
Max. screw stroke	mm / in	40 / 1.57	80 / 3.15	95 / 3.74		
Nozzle force / contact pressure	US Tons	2.25	2.7	2.7		
Nozzle retraction stroke	mm / in	100 / 3.94	205 / 8.07	205 / 8.07		
Screw torque	ft / lbf	55.32 (1668 psi)	132.76 (6.1 in <sup>3</sup> /1885 psi)	132.76 (6.1 in <sup>3</sup> /1885 psi) / 213.89 (9.8 in <sup>3</sup> /1885 psi)		
Screw speed (infinitely variable)	rpm	340 (3.1 in <sup>3</sup> )	300 (4.9 in <sup>3</sup> ) / 250 (6.1 in <sup>3</sup> )	250 (6.1 in <sup>3</sup> ) / 160 (9.8 in <sup>3</sup> )		
Screw pullback force	US Tons	0.9	4.95	4.95		
Heating power (Nozzle, socket + cylinder)	W	1575	4850	8100		
Hopper capacity	Us gal.	0.79	3.43	3.43		
Injection speed	in / sec	7.87	3.58	3.58		

General			
Total power	V / Amps / 3 phase	230 V / 20 A / 3 phase	
Duration of the dry cycle acc. to EUROMAP 6 (stroke)	s (mm)	–	–
Hydraulic system pressure	psi	3626	3046
Oil tank capacity	US gal.	7.4	7.4

Dimensiones and weights		2C XS	2C S
Dimensions (LxWxH) / Footprint	in / square in	41.85 x 21.54 x 83.31 <sup>2</sup> / 901	65.63 x 28.23 x 75.79 <sup>2</sup> / 1853
Total weight net (without oil)	lb	705	930
Total weight gross (pallet & foil / wooden crate)	lb	877 / 1076	1146 / 1676
Transport dimensions / case (LxWxH)	in	66.9 x 27.6 x 90.6 / 66.9 x 27.6 x 88.6	90.6 x 41.7 x 86.6 / 78.7 x 39.4 x 70.9

<sup>1)</sup> more injection units see Technical Data and Equipment    <sup>2)</sup> in Stand-by-Position



Control

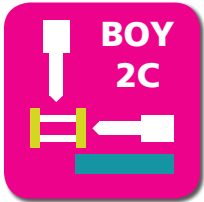

Multi Component

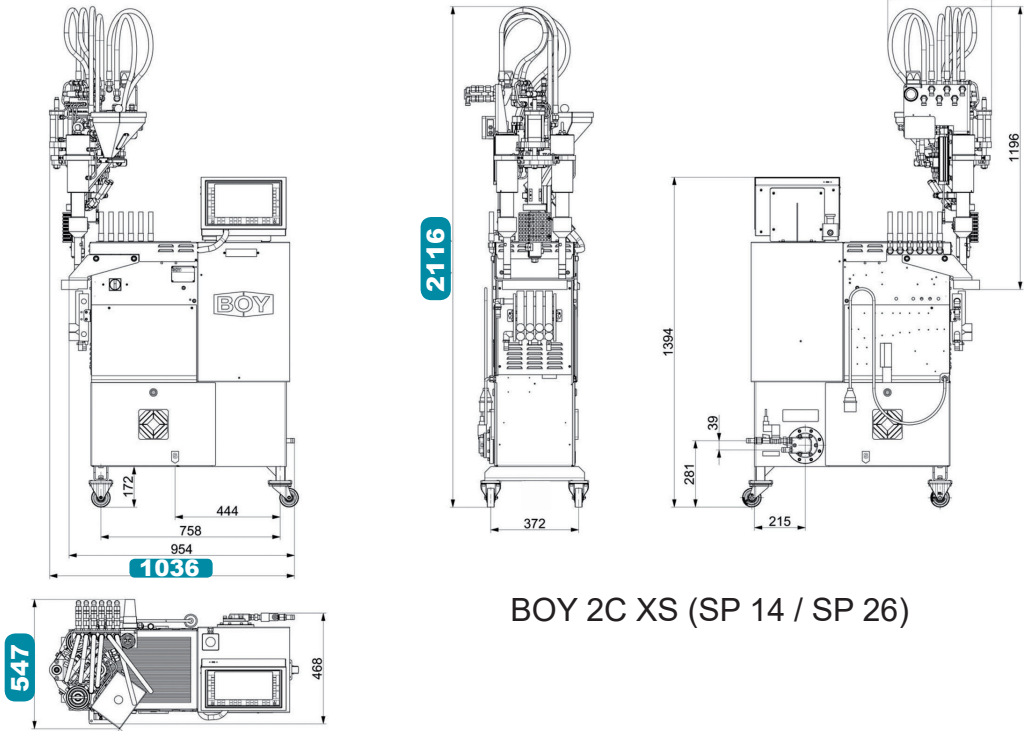

BOY 2C XS (SP 14 / SP 26)

Equipment

Injection unit

Pivoting injection unit	-
Preset screw speed values with ramping transition	■
Cold start protection	■
Number of set points of injection speed	9
Number of set points of injection pressure	9
Start of holding pressure dependent on hydraulic pressure, stroke and time	■
Start of holding pressure, cavity pressure-dependent	□
Number of set points of holding pressure	9
Production monitoring at start of holding pressure	■
Closed loop control for the complete injection profile and back pressure	■
Control for intrusion-injection (not for BOY 2C XS)	■
PID microprocessor-controlled heating zones for cylinder + nozzle set and temp. display	□
Hydraulically actuated needle shut-off nozzle (pneumatic for XS-LSR)	○
Slide-away for quick material change (25 + 35 + 60 VV / 35 HV / 2C M without hopper)	-/□
Automatic material loader / feeder	□
Adjustable nozzle force	■
Delayed nozzle retraction	■
Servo-electric screw drive (separate feed line required)	-
High wear-resistant plasticizing units	-
High wear-resistant EconPlast unit	-
Speed injection (not for BOY 2C XS)	○
Clamping force build-up can be activated parallel to injection	-
Electromechanical injection movement	-

Clamping unit

Number of set points of mold closing / opening speed	9
Core pull control with 4/3 way directional control valve and freely selectable operational programmes	□
Air ejection	□

■ standard    ○ alternatively    □ optional    - not available

Electronics

USB interface for access and data exchange	■
Interface kit: Serial/Temperature device, USB and Ethernet	□
OPC interface	□
4 freely programmable inputs/outputs	□
Piece counter	-
Preselect cycle counter with auto shut-off	-
Grounded socket outlet 230 V ~ / 10 A, (alternatively switched)	■(-)
CEE socket outlet 400 V ~ / 16 A (alternatively switched)	-(-)
Socket distributor 400 V ~ switched + 230 V ~ (Standard supply 32 A)	□
Socket distributor 400 V ~ / 230 V ~ switched (separate feed line required)	□
Energy distributor with four fixed connections, up to 5 x 400 V CEE + 3 x 230 V (sockets can be switched off optionally). Standard supply 125 A / 5 x 50 mm <sup>2</sup>	-
Switch cabinet ventilation	■
Standardized interface for handling units EUROMAP 67	-
Separate feeder (heating and motor current)	-
7-day timer	■
Additional temperature control	□
Brush control	-
Connector for safety switch to inhibit mold closing	-
Integrated hot runner control, 8/16-fold (separate feed line required)	-
Air conditioning unit for control cabinet	-
Alarm signal with sound	□

Hydraulics

Electronically controlled variable pump	■
Servo-motor pump drive (Servo-drive)	-
Oil preheating circuit automatic	■
Oil temperature gauge / Controlled oil cooling / Oil level indicator	■
Oil level and temperature monitoring	■
Proportional valve with stroke feedback and positioning action for clamp unit	-

General

Cooling water distributor with electric shut-off valve for injection mold	-
Temperature control for feet throat	□
6- / 8-zone water distributor	-
Tool kit	□
Spare parts package	□
Oil filling	□
Anti-vibration mounts	■

You would like to learn more about this BOY injection unit?



Boy Machines, Inc.  
 199 Philips Road  
 Exton, Pennsylvania 19341

Spritzgiessautomaten

Phone: (610) 363-9121  
 Fax: (610) 363-0163  
 sales@boymachines.com  
 www.boymachines.com



BOY-APP  
 free of charge at  
<http://app.dr-boy.de>

